

Mirrorcle Technologies, Inc. Product List

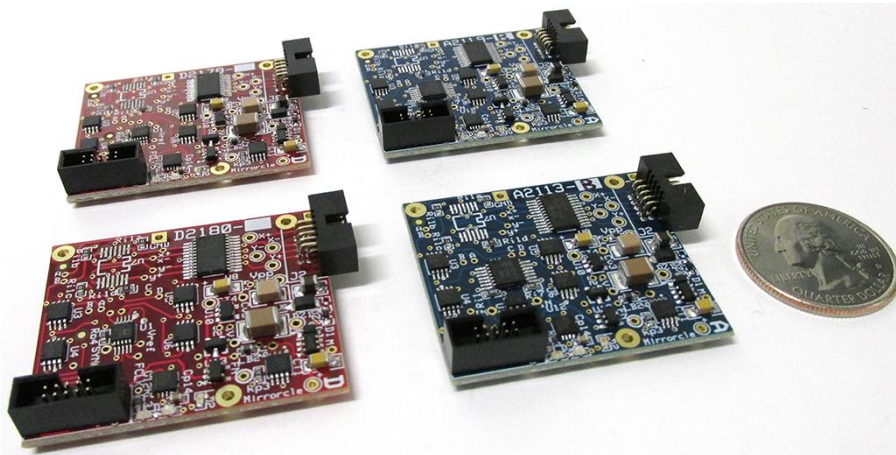

mirrorcle
TECHNOLOGIES, INC.

Mirrorcle Technologies, Inc.

Richmond, CA
December, 2019

Mirrorcle Products

□ Development Kits (and Add-Ons)

- DK-15: Standard Dev Kit
- DK-16: Semi-Custom Dev Kit
- DK-30: Dev Kit with Scan Module
- DK-26: LiDAR/Imaging MEMS Dev Kit I
- DK-27: LiDAR/Imaging MEMS Dev Kit II

□ Playzer Development Kits

- PZDK-02: Monochrome Playzer Dev Kit
- PZDK-03: RGB Playzer Dev Kit

□ Demonstrator Kits

- DEMO-01: Laser Tracking and MEMS Mirror
- DEMO-02: Laser Scan and Camera Sense
- DEMO-04: Video Rate Projection and Imaging
- DEMO-06: 3D Scanning
- DEMO-07: SyMPL 3D MEMS Mirror LiDAR

□ MEMS Mirrors

- Single Axis mirrors
- Dual Axis mirrors

□ Scan Modules

□ Electronics

- MEMS Controllers
- MEMS Drivers

□ Software

- Mirrorcle Software Suite
- Software Development Kits



Development Kits

Mirrorcle Development Kits

Development Kits

- Mirrorcle Standard Development Kit (P/N: DK-015)
- Mirrorcle Semi-Custom Development Kit (P/N: DK-016)
- Mirrorcle Development Kit with a Scan Module (P/N: DK-030)
- LiDAR/Imaging MEMS Dev Kit I (P/N: DK-026)
- LiDAR/Imaging MEMS Dev Kit II (P/N: DK-027)

Add-ons

- Wireless Option
- PSD Bundle
- Wide-Angle-Lens
- Laser Tracking Bundle
- Android Development Kit (Includes Wireless Option)
- Linux Development Kit
- Python Software Development Kit

Mirrorcle Development Kits Overview

- Mirrorcle Standard Development Kit (P/N: DK-015)
 - Standard Dev Kit has the three mirror sizes and actuators are preselected and premanufactured to **reduce cost and delivery time**.
- Mirrorcle Semi-Custom Development Kit (P/N: DK-016)
 - Semi-Custom Dev Kit allows **users can select** among **various available actuators, mirror size** and **coating** combinations to best suit their application.
- Mirrorcle Development Kit with a Scan Module (P/N: DK-030)
 - Dev Kit with Scan Module includes the EaZy 2.0 scan module, a **pre-assembled optomechanical cell** with MEMS mirror, laser module and with wide-angle optics, for rapid prototyping with a **complete optical solution**.

LiDAR/Imaging MEMS Development Kits Overview

- LiDAR/Imaging MEMS Dev Kit 1 (P/N: DK-026)*
 - Large diameter, large angle MEMS mirrors, typically used in coaxial designs with both illumination/transmit and sense/receive paths going through the MEMS mirror.
- LiDAR/Imaging MEMS Dev Kit 2 (P/N: DK-027)*
 - Medium diameter, large angle MEMS mirrors, fastest and most robust, typically used in biaxial/bistatic designs only on illumination/transmit paths, or in shorter distance coaxial designs.

*LiDAR/Imaging MEMS development kits are for developers of systems such as **OCT/Confocal** imaging systems, **LiDARs**, **3D Scanning**, and include MEMS Mirrors and supporting hardware and software to assist developers in integration into complete prototypes and/or products.

For a fully functional 3D LiDAR demonstrator kit see **DEMO-07** in a later section in this document.

Note on Kit Pricing: as bundled, the LiDAR/Imaging Kits offer a nearly **\$1000 discount** from the list pricing of equivalent items (in a Semi-Custom kit with identical selections). This is offered along with **shorter lead times** however contents **cannot be modified**.

Mirrorcle Standard Development Kit



Standard Development Kit - Contents

- **Three Gimbal-less Dual-Axis MEMS Mirrors**
 - 1.2mm, 2mm, 3.6mm diameter, Aluminum coated
- **USB MEMS Controller**
 - Includes all necessary cables and connectors
- **Mirrorcle Software Suite**, with comprehensive documentation + support hours
- **Laser and Optical Breadboarding**
 - Red Laser module – with TTL modulation input
 - 90° optical mount for the laser module on a 1/2"-diameter post
 - 4.5" x 4.5" optical plate and two post holders
 - MEMS Mount "Horseshoe" (anodized aluminum) mounted on a kinematic mount (2-axis) and a 1/2"-diameter post. Includes screws and L-key.
- **OPTIONAL Add-ons listed on Development Kit Optional Add-Ons page**

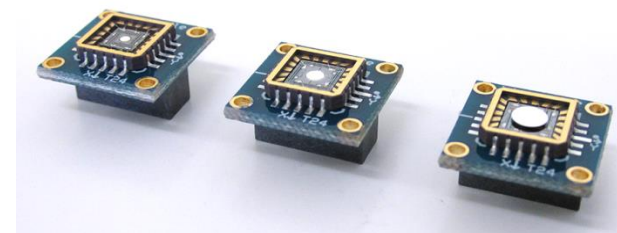

MEMS Mirrors in the Standard Development Kit
(TINY20.4 connectorized packages)

Development Kit with Scan Module



Development Kit with Scan Module - Contents

- **EaZy2.0R Scan Module**
 - Optomechanical cell with MEMS mirror, laser and optics
- **USB MEMS Controller**
 - Includes all necessary cables and connectors
- **Mirrorcle Software Suite**, with comprehensive documentation + support hours
- **Laser and Optical Breadboarding**
 - Red Laser module – with TTL modulation input
 - 90° optical mount for the laser module on a 1/2”-diameter post
 - 4.5” x 4.5” optical plate and two post holders
 - MEMS Mount “Horseshoe” (anodized aluminum) mounted on a kinematic mount (2-axis) and a 1/2”-diameter post. Includes screws and L-key.
- **OPTIONAL Add-ons listed on Development Kit Optional Add-Ons page**

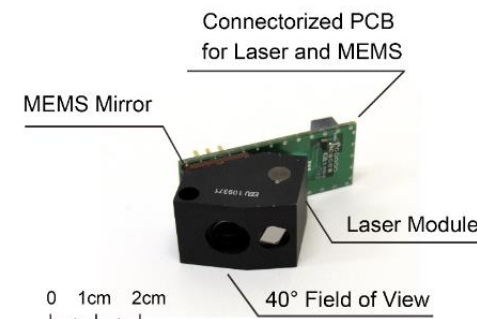

LiDAR/Imaging MEMS Dev Kit I (DK-026)

- **Four Gimbal-less Dual-Axis MEMS Mirrors**
 - 4.6mm, 4.6mm, 5.0mm, Gold coated
- **USB MEMS Controller**
 - Includes all necessary cables and connectors
- **Mirrorcle Software Suite**, with comprehensive documentation + support hours
- **Laser and Optical Breadboarding**
 - Red Laser module – with TTL modulation input
 - 90° optical mount for the laser module on a 1/2"-diameter post
 - 4.5" x 4.5" optical plate and two post holders
 - MEMS Mount "Horseshoe" (anodized aluminum) mounted on a kinematic mount (2-axis) and a 1/2"-diameter post. Includes screws and L-key.
- **OPTIONAL Add-ons listed on Development Kit Optional Add-Ons page**

LiDAR/Imaging MEMS Dev Kit II (DK-027)

- **Four Gimbal-less Dual-Axis MEMS Mirrors**
 - 2.0mm, 2.0mm, 2.4mm, 2.4mm diameter, Aluminum coated
- **USB MEMS Controller**
 - Includes all necessary cables and connectors
- **Mirrorcle Software Suite**, with comprehensive documentation + support hours
- **Laser and Optical Breadboarding**
 - Red Laser module – with TTL modulation input
 - 90° optical mount for the laser module on a 1/2”-diameter post
 - 4.5” x 4.5” optical plate and two post holders
 - MEMS Mount “Horseshoe” (anodized aluminum) mounted on a kinematic mount (2-axis) and a 1/2”-diameter post. Includes screws and L-key.
- **OPTIONAL Add-ons listed on Development Kit Optional Add-Ons page**

Playzer Development Kits

The listed products in this section are intended for development and prototyping purposes as an **OEM** subsystem for incorporation into customer's prototypes and end products. Therefore, they do not comply with the appropriate requirements of FDA 21 CFR, section 1040.10 and 1040.11 for complete laser products.

Playzer Development Kits

Development Kits

- Monochrome Playzer Development Kit [P/N: PZDK-02(R/G/B/V) OEM]
- RGB Playzer Development Kit [P/N: PZDK-03RGB OEM]

Additional Playzer Modules

- PZ-02(R/G/B/V) OEM – Available after purchase of a PZDK

Playzer Development Kit 02 (PZDK-02 OEM)

- **PZDK-02x OEM Playzer Development Kit** is a demonstration and development bundle using Mirrorcle's Vector Graphics Laser Projection (**VGLP**) technology consisting of a **Playzer Module**, Windows **Software Applications**, and **Software Development Kits** in C++, Matlab, and LabView. **Playzer Module PZ-02 OEM** has a **fast MEMS mirror**, giving **several kHz of graphics bandwidth**. The Kit allows a plug-and-play, simple and playful environment for testing of displaying and other programmable monochrome laser applications.
- This development kit is intended for development and prototyping purposes as an **OEM** subsystem for incorporation into customer's prototypes and end products. Therefore, it does not comply with the appropriate requirements of FDA 21 CFR, section 1040.10 and 1040.11 for complete laser products.



All photographs are of actual displaying examples using PZDK-02

Playzer Development Kit 02 (PZDK-02 OEM) - Contents

Features and Specifications:

- VGLP, display vector content at $\geq 40\text{Hz}$ rate
- R/G/B/V laser, 3-6mW, 1-bit Digital Modulation
- Approx. $40^\circ \times 40^\circ$ Field of View
- $< 0.01^\circ$ Beam position repeatability
- MEMS Mirror: A7M10.2-1000AL
- USB Interfaced and Powered
- $< 1000\text{mW}$ Power Consumption

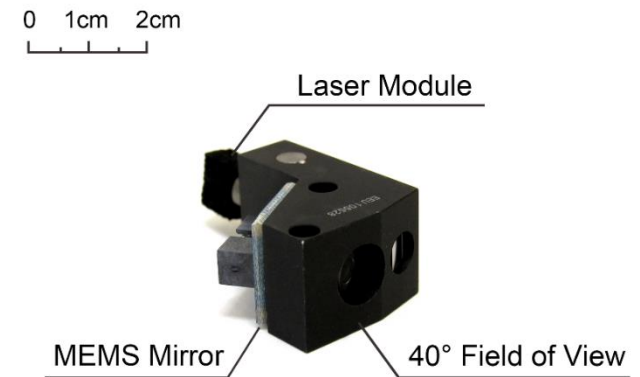

Mirrorcle Software Suite

- MirrorcleDraw
- MTIDevice-Demo
- MirrorcleLinearRaster
- MirrorcleListDevices
- Full SDKs for C++, Matlab, LabView

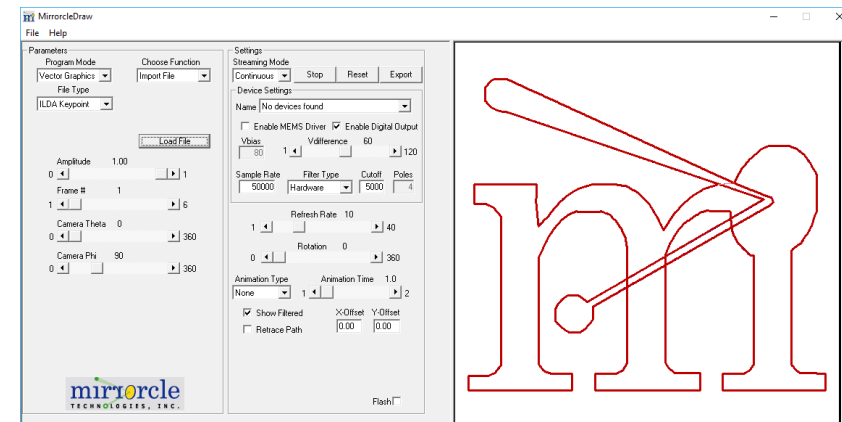

RGB Player Development Kit (PZDK-03 OEM)

- **PZDK-03RGB OEM** or **Playzer Development Kit** is a demonstration and development bundle using Mirrorcle's Vector Graphics Laser Projection (**VGLP**) technology consisting of an **RGB Playzer Module**, Windows **Software Applications**, and **Software Development Kits** in C++, Matlab, and LabView. **Playzer Module PZ-03RGB OEM** has a **fast MEMS mirror**, giving **several kHz of graphics bandwidth**. The Kit allows a plug-and-play, simple and playful environment for testing of displaying and other programmable laser applications. The module includes three laser sources(R | G | B), each with 8-bit digital modulation, that are combined in free-space.
- This development kit is intended for development and prototyping purposes as an **OEM** subsystem for incorporation into customer's prototypes and end products. Therefore, it does not comply with the appropriate requirements of FDA 21 CFR, section 1040.10 and 1040.11 for complete laser products.

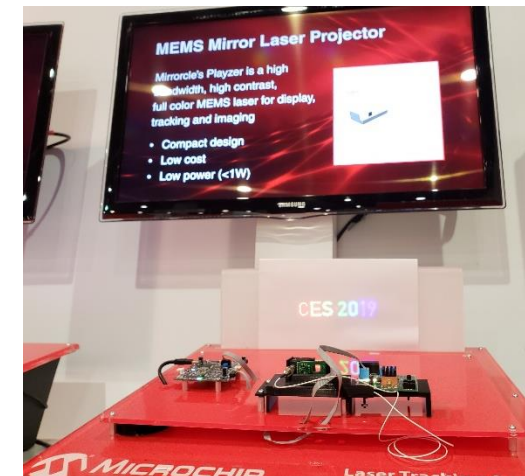
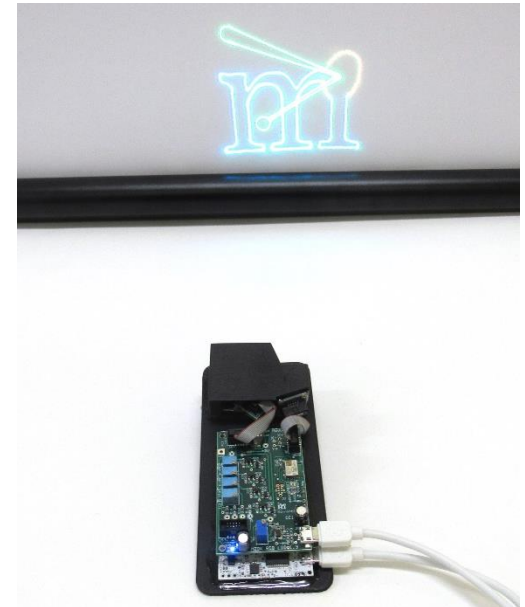

RGB Player Development Kit (PZDK-03 OEM) - Contents

Features and Specifications:

- ❑ VGLP, display vector content at ≥ 50 Hz rate
- ❑ R, G, and B laser, 3-6mW, 8-bit Digital Modulation
- ❑ Analog brightness control of R, G, and B lasers
- ❑ Approx. $32^\circ \times 32^\circ$ Field of View
- ❑ $< 0.01^\circ$ Beam position repeatability
- ❑ MEMS Mirror: A7M10.2-1000AL
- ❑ USB Interfaced and Powered
- ❑ < 1250 mW Power Consumption

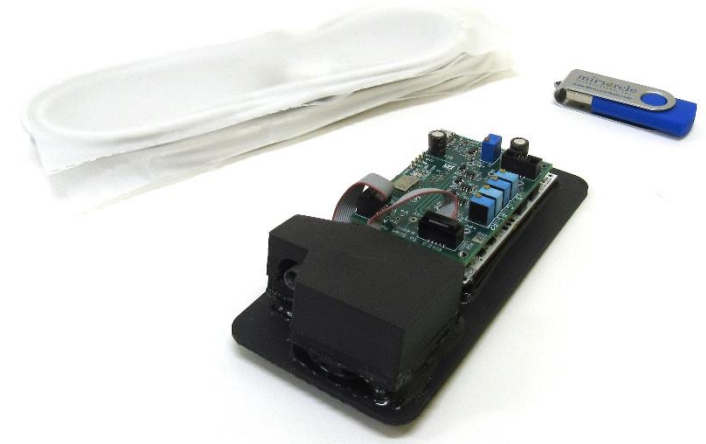

Mirrorcle Software Suite

- ❑ MirrorcleDraw
- ❑ MTIDevice-Demo
- ❑ MirrorcleLinearRaster
- ❑ MirrorcleListDevices
- ❑ Full SDKs for C++, Matlab, LabView

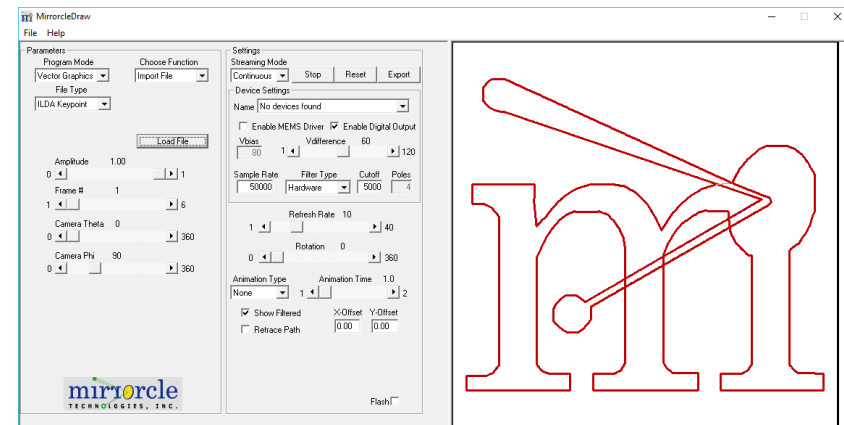



Demonstrator Kits

Laser Tracking and MEMS Mirror Demonstrator Kit (DEMO-01)



Laser Tracking and MEMS Mirror Demonstrator Kit (DEMO-01) - Contents

- EaZy 2.0 **Scan Module** - optomechanical cell with MEMS mirror, laser and optics

- MEMS Mirror: A3I1 2.2-1 200AL-T0822/H1 280-NOCAP
- Green Laser module (3-10mW CW Power) with TTL modulation
- Wide Angle Lens and optics with 40° optical FoV

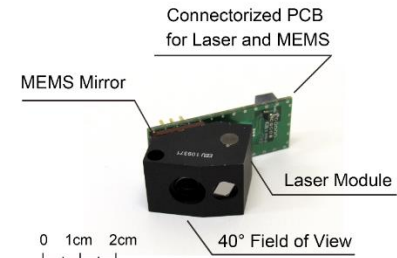

- **Photosensor** with optical filter and 60° FoV lens, pigtailed cable

- “USB-SL MZ” **USB MEMS Controller**

- PIC32MZ MCU and Embedded MEMS driver
- USB powered
- Optional (Add-On) wireless communication with Bluetooth



- Mirrorcle **Software Suite** comprehensive documentation

- Windows Applications, 3 SDKs
- Four Software **Support Hours** (Additional hours available for purchase)

Laser Scan and Camera Sense Demonstrator Kit (DEMO-02)

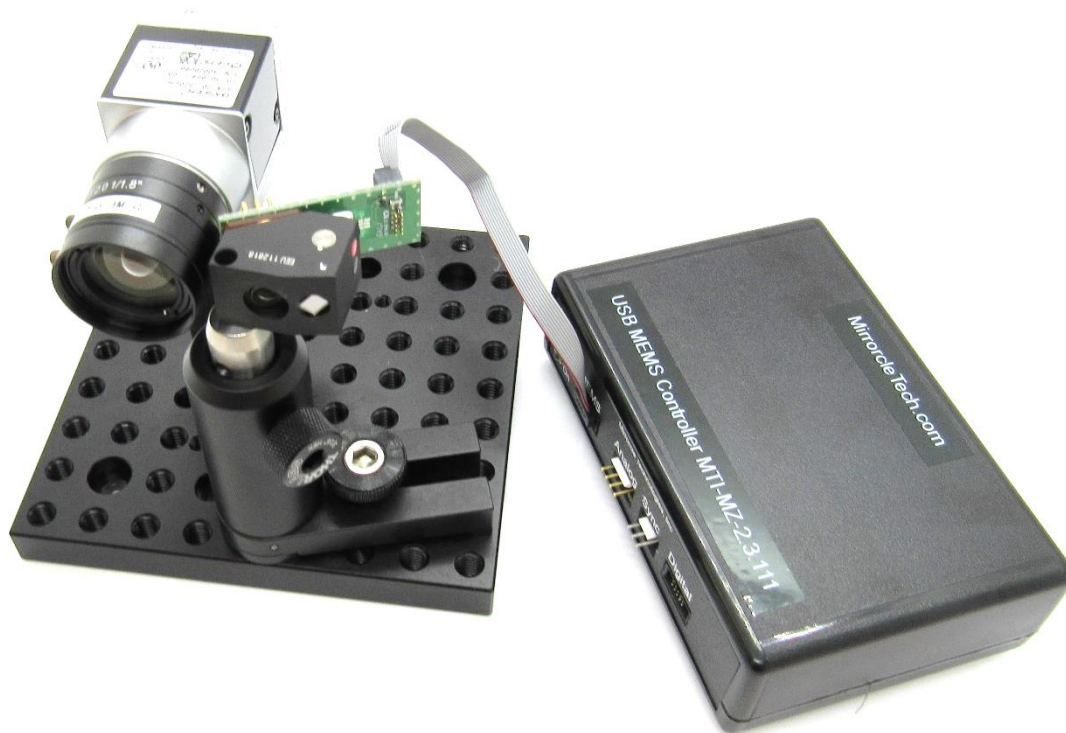

DEMO-02 Kit Contents Overview

- EaZy 2.0 **Scan Module** - optomechanical cell with mirror, laser and optics
 - MEMS Mirror: A3I12.2-1200AL-T0822/H1280-NOCAP
 - Green Laser module (3-10mW CW Power) with TTL modulation
 - Wide Angle Lens and optics with 40° optical FoV
 - Cable for laser and MEMS mirror attached
- **USB 3.0 Camera** with 6mm lens (~45° x 34.5° FoV)
 - 720x540 pixels, capable of >500 fps
- Mechanical mounting for Camera and Scan Module
- USB-SL MZ **MEMS Controller** with Embedded MEMS driver
- Mirrorcle **Software Suite** + Camera Sense API
 - With comprehensive documentation
- Software examples specific to DEMO-02

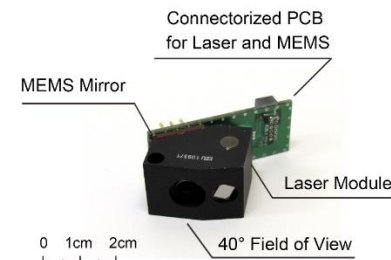

Video Rate Projection and Imaging Demonstrator Kit (DEMO-04)

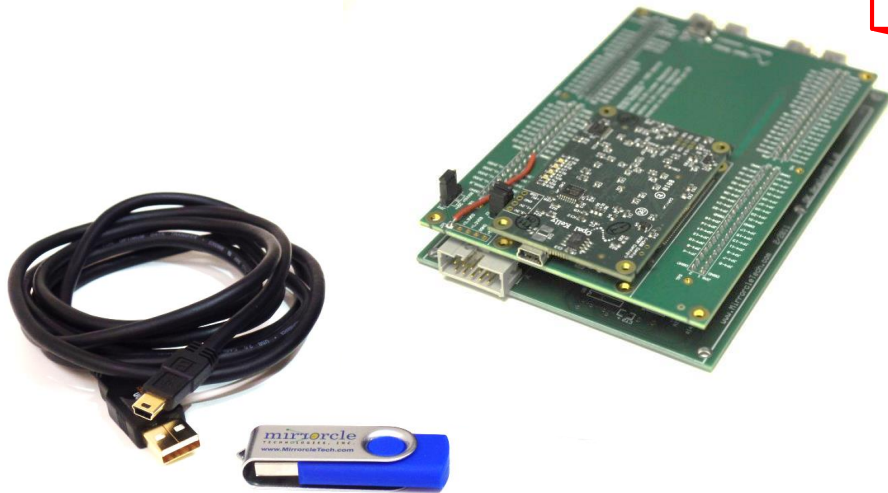

FPGA based MEMS Controller
and Software on USB

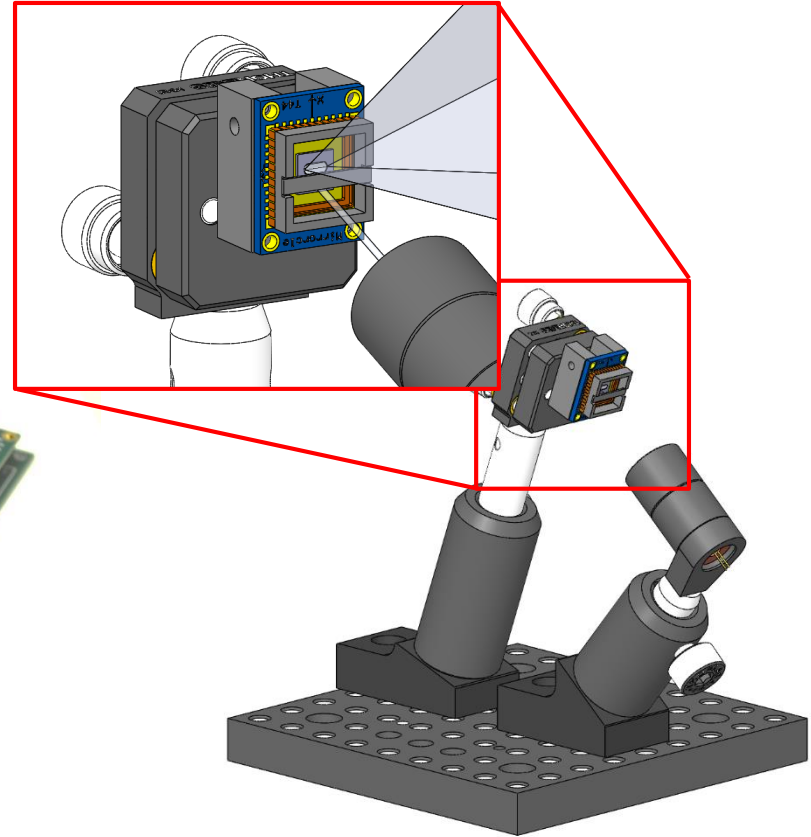

Optical Breadboarding with
mounting for MPM and laser module

DEMO-04 Kit Contents Overview

- MPM – **MEMS Pair Module**
 - MEMS1 – 0.9mm mirror
 - MEMS2 – 3.2mm x 1.3mm elongated mirror
- Cable for laser and MEMS mirror
- LM – **Laser Module (Single Color)**
 - Green ~520nm, ~20-40mW
 - Modulation capability >100MHz
 - Mounted with beam reducer to <1mm diameter
- Controller – **FPGA-based controller** with USB interface
 - Embedded MEMS driver
- Software
 - Matlab-based GUI application for scan parameter exploration
 - Windows-based console demo application

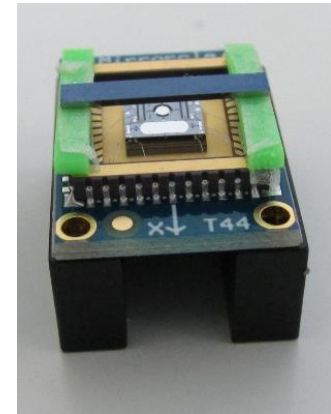

3D Scanning Demonstrator Kit (DEMO-06)



DEMO-06 Kit Contents Overview

- EaZy 2.0 **Scan Module** - optomechanical cell with mirror, laser and optics
 - MEMS Mirror: A3I12.2-1200AL-T0822/H1280-NOCAP
 - Red Laser module (3-10mW CW Power) with TTL modulation
 - Wide Angle Lens and optics with 40° optical FoV
 - Cable for laser and MEMS mirror attached
- **USB 3.0 Camera** with 8mm lens (~34.5° x 26.2° FoV)
 - 720x540 pixels, capable of >500 fps
- Mechanical mounting for Camera and Scan Module
- USB-SL MZ **MEMS Controller** with Embedded MEMS driver
- Mirrorcle **Software Suite** + Camera Sense API
 - With comprehensive documentation
- Software examples specific to DEMO-06

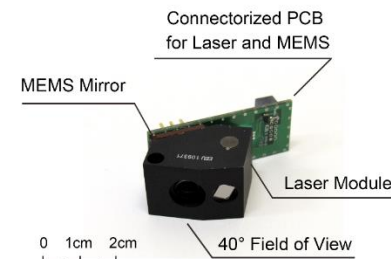

SyMPL MEMS Mirror 3D LiDAR Demonstrator Kit (DEMO-07)



Software on USB



SyMPL system + USB Micro Cable

DEMO-07 Kit Contents Overview

- **SyMPL 3D LiDAR system** with user-configurable region of interest (up to $30^\circ \times 30^\circ$)
- Software Applications (Windows)
 - **MirrorcleLiDAR**
 - **MirrorcleCloud**
- Accessories
 - 1x **USB Micro Cable** for power and data

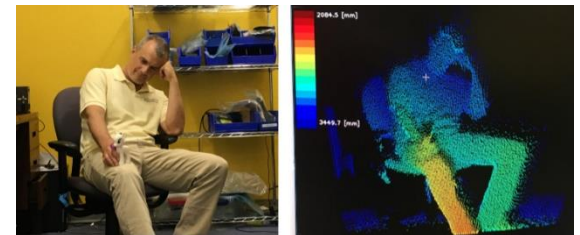
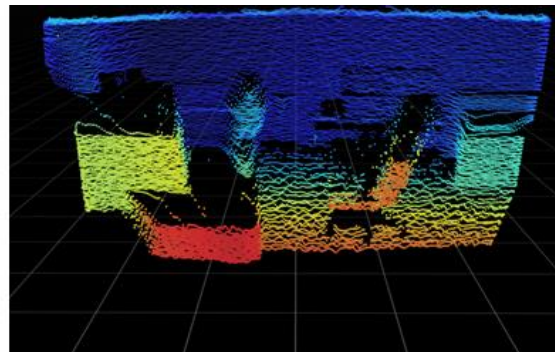
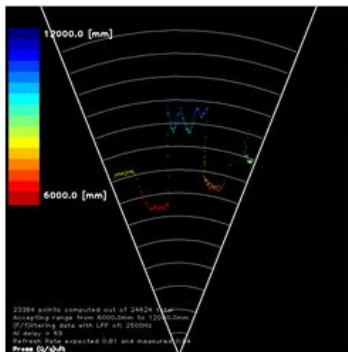
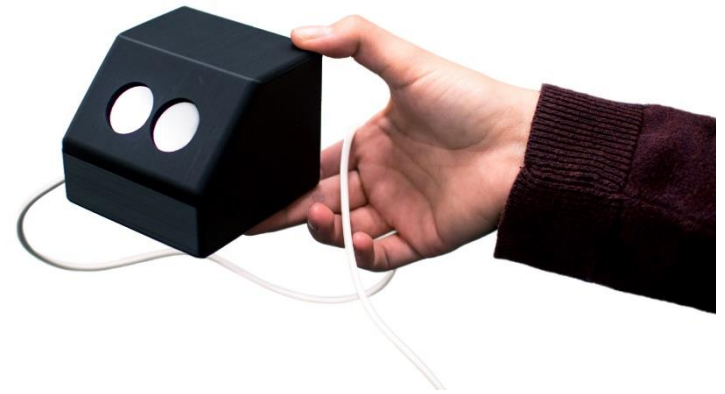



MEMS Mirrors

Mirrorcle MEMS Mirrors

□ Single-Axis

- Resonant
- Point-to-Point (Quasistatic)
 - In addition to a number of single-axis specific products, most quasistatic dual-axis designs can be assembled/tested/shipped in single-axis configuration.

□ Dual-Axis (point-to-point)

- Integrated Mirrors
- Bonded Mirrors

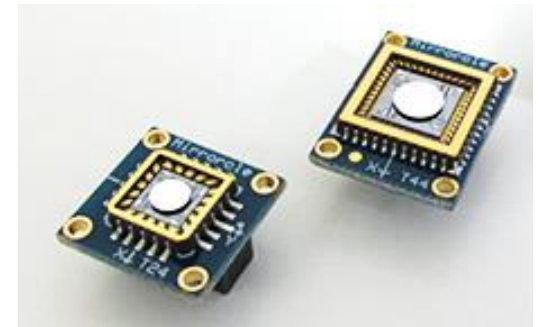
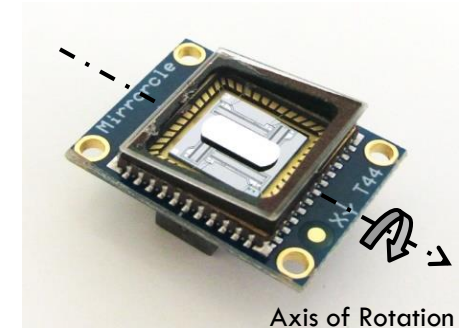

Single Axis MEMS Mirrors

Single Axis, Point-to-Point (Quasistatic)					
Actuator Size	Actuator Type	Mech. Angle	Package	Resonant Freq.	Mirror Sizes
5.2 x 5.2mm	A9Q40.1	$\pm 4.5^\circ$	TINY20.4	~1.8kHz	Integrated 4mm x 1.3mm
5.2 x 5.2mm	A9S1.1	$\pm 6^\circ$	TINY20.4	varies	Bonded up to 3.6mm
5.2 x 5.2mm	A9S2.1	$\pm 5^\circ$	TINY20.4	varies	Bonded up to 3.6mm
7.25 x 7.25mm	A8L2.2S	$\pm 5^\circ$	TINY48.4	varies	Bonded up to 6mm
7.25 x 7.25mm	A5L2.1S	$\pm 1^\circ$	TINY48.4	varies	Bonded up to 7.5mm

Single Axis, Resonant					
Actuator Size	Actuator Type	Mech. Angle	Package	Resonant Freq.	Mirror Sizes
4.25 x 4.25mm	A1R8.x	$\pm 7.5^\circ$	TINY20.4	~21 kHz	Integrated 0.8mm (ellip.)
5.2 x 5.2mm	A1R10.5	$\pm 6^\circ$	TINY20.4	~15 kHz	Integrated 1.0mm
5.2 x 5.2mm	A9R8.1	$\pm 7.5^\circ$	TINY20.4	~24 kHz	Integrated 0.8mm (ellip.)
5.2 x 5.2mm	A9R12.1	$\pm 7.5^\circ$	TINY20.4	~12.8 kHz	Integrated 1.2mm (ellip.)

Quasistatic Single Axis MEMS Mirrors Examples

Quasistatic Elliptical and Round Mirrors (point to point):

- **A9S1.1**, mech. angle $\pm 6^\circ$, for various bonded mirrors
 - With elliptical E2800 mirror (2.8mm x 2.0mm) has $\sim 850\text{Hz}$ resonance
- **A9S2.1**, mech. angle $\pm 5^\circ$, for various bonded mirrors
 - With elliptical E2800 mirror (2.8mm x 2.0mm) has $\sim 1000\text{Hz}$ resonance
- For smaller mirrors than E2800, recommend using integrated dual-axis devices (with one axis frozen for single-axis operation).

A9S2.1-E2800AL example

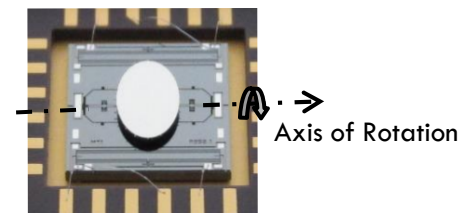

A9S2.1-2000AL example

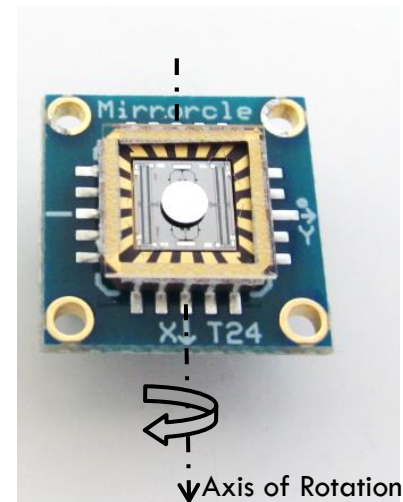

Quasistatic Single Axis MEMS Mirrors Examples

Quasi-static LINE mirrors are typically used in **LiDAR applications**, such as with scanning an emitter array in one axis, or as a second axis mirror with a two-single-axis (2SA) mirror setup, rastering on the fast axis, and quasistatic scan on the slow axis.

□ **A9Q40.1-4000x1300AL-TINY20.4**

- Rotates about the long axis, $\pm 4.5^\circ$, first resonance $\sim 2000\text{Hz}$
- Typically used as the 2nd mirror in with 2SA scanned LiDARs, picoprojectors, 3D sensing

□ **A8L2.2-6000x2400AL-TINY48.4**

- Rotates about the long axis, $\pm 5^\circ$, first resonance $\sim 500\text{Hz}$
- Typically used with emitter array based LIDARs

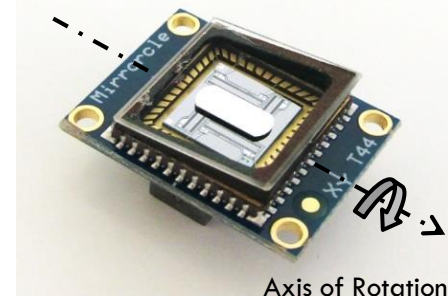
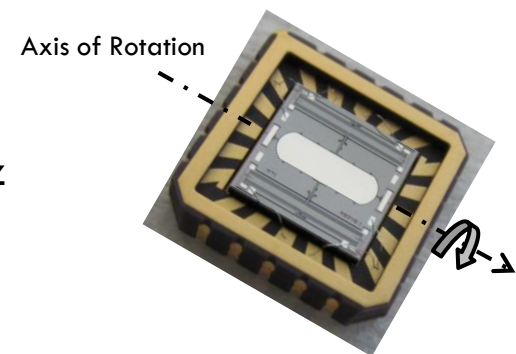

Single Axis MEMS Mirrors: Resonant

Newest Designs:

□ A9R12.1-1200DAL-TINY20.4

- $\pm 7.5^\circ$ max mechanical angle, around 12.8kHz resonance

□ A9R8.1-800DAL-TINY20.4

- $\pm 7.5^\circ$ max mechanical angle, around 24kHz resonance

Older Designs:

□ A1R10.5-1000DAL-TINY20.4

- $\pm 6^\circ$ max mechanical angle, around 15kHz resonance

□ A1D.4-800DAL-TINY204

- $\pm 7.5^\circ$ max mechanical angle, around 21kHz resonance

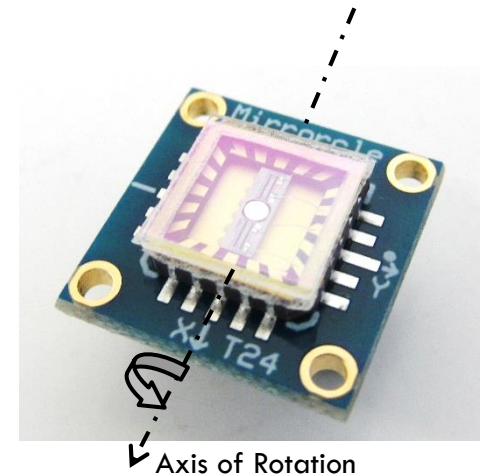

Dual Axis MEMS Mirrors - Integrated

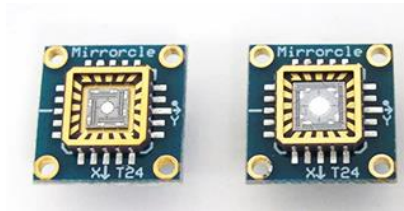

Dual Axis, Integrated Quasistatic					
Actuator Size	Actuator Type	Mech. Angle	Package*	Resonant Freq.	Mirror Sizes
4.25 x 4.25mm	A3I8.2	$\pm 6^\circ$	TINY20.4	~ 3.6 kHz	0.8mm
5.2 x 5.2mm	A7M8.1	$\pm 4.75^\circ$	TINY20.4	~ 6 kHz	0.8mm
5.2 x 5.2mm	A7M10.2	$\pm 4.75^\circ$	TINY20.4	~ 4.5 kHz	1.0mm
4.25 x 4.25mm	A3I12.2	$\pm 5^\circ$	TINY20.4	~ 2.6 kHz	1.2mm
5.2 x 5.2mm	F1M16.1	$\pm 5^\circ$	TINY20.4	~ 1.7 kHz	1.6mm
5.2 x 5.2mm	A7M20.2	$\pm 4.8^\circ$	TINY20.4	~ 1.25 kHz	2.0mm
7.25 x 7.25mm	A5M24.2	$\pm 5^\circ$	TINY48.4	~ 800 Hz	2.4mm

Note: All above designs are point-to-point or quasistatic and the natural resonant frequency is listed only as a reference for comparison of their respective available bandwidths. Bandwidth for driving with arbitrary waveforms depends on the driving and control method and is up to about 1.4X resonant frequency.

*Listed package is the smallest applicable package for that design, larger packages (TINY48.4 and DIP24) apply for any design.

Dual Axis MEMS Mirrors - Bonded

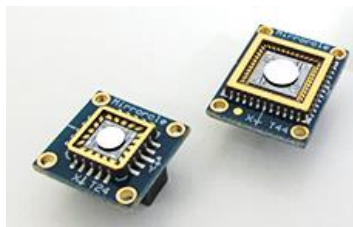

Dual Axis, Bonded Quasistatic					
Actuator Size	Actuator Type	Mech. Angle	Package*	Resonant Freq.	Bonded Mirror Sizes
5.2 x 5.2mm	A7B1.1	$\pm 7^\circ$	TINY20.4	Varies w/ size	2.0, 2.4, 3.0, 3.6mm
5.2 x 5.2mm	A7B2.1	$\pm 5.5^\circ$	TINY20.4	Varies w/ size	2.4, 3.0, 3.6mm
7.25 x 7.25mm	A5L2.2	$\pm 1^\circ$	TINY48.4	Varies w/ size	2.0, 2.4, 3.0, 3.6, 4.2, 4.6, 5.0, 6.4, 7.5mm
7.25 x 7.25mm	A5L3.3 (C1)	$\pm 2.5^\circ$	TINY48.4	Varies w/ size	2.0, 2.4, 3.0, 3.6, 4.2, 4.6, 5.0, 6.4mm
7.25 x 7.25mm	A5L3.3 (C2)	$\pm 4.25^\circ$	TINY48.4	Varies w/ size	2.0, 2.4, 3.0, 3.6, 4.2, 4.6, 5.0mm
7.25 x 7.25mm	A8L2.2	$\pm 5^\circ$	TINY48.4	Varies w/ size	3.0, 3.6, 4.2, 4.6, 5.0mm

Note: Bonded mirror mech. angle. may be limited by mirror size

*Listed package is the smallest applicable package for that design, larger packages (TINY48.4 and DIP24) apply for any design.

MEMS Mirror Coatings

- Bonded MEMS Mirrors are offered with pure Aluminum (Al) or pure Gold (Au) coating. Thin films coatings are extremely smooth, high optical quality.
- All integrated MEMS mirrors are available in Al coatings
- There are no other coatings available with this technology, however in special cases customers may purchase uncoated mirrors. (polished silicon surface)

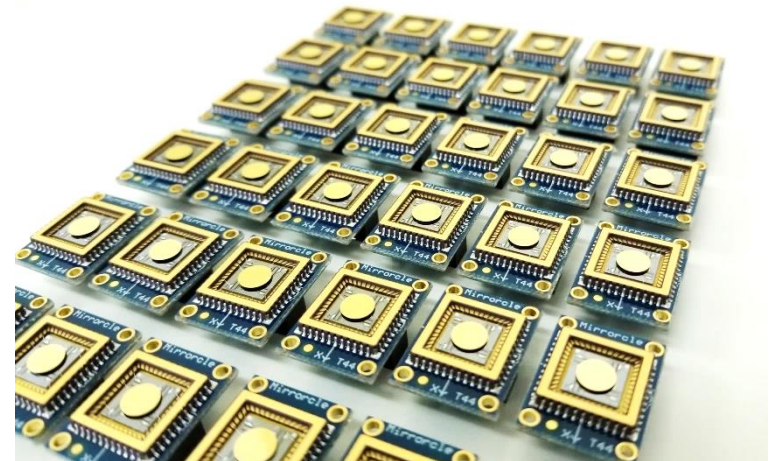
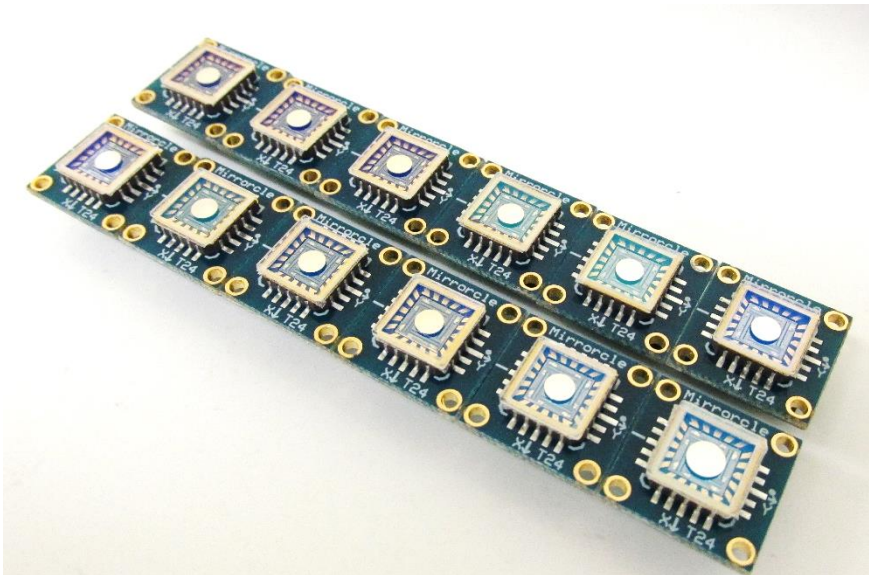

MEMS Mirror Packages and Mounts

- Available packages are, TINY20.4, TINY48.4, DIP24
- See detailed MEMS Packages and Mounts Guide:
[http://mirrorcletech.com/pdf/Mirrorcle MEMS Packages and Mounts Guide.pdf](http://mirrorcletech.com/pdf/Mirrorcle%20MEMS%20Packages%20and%20Mounts%20Guide.pdf)

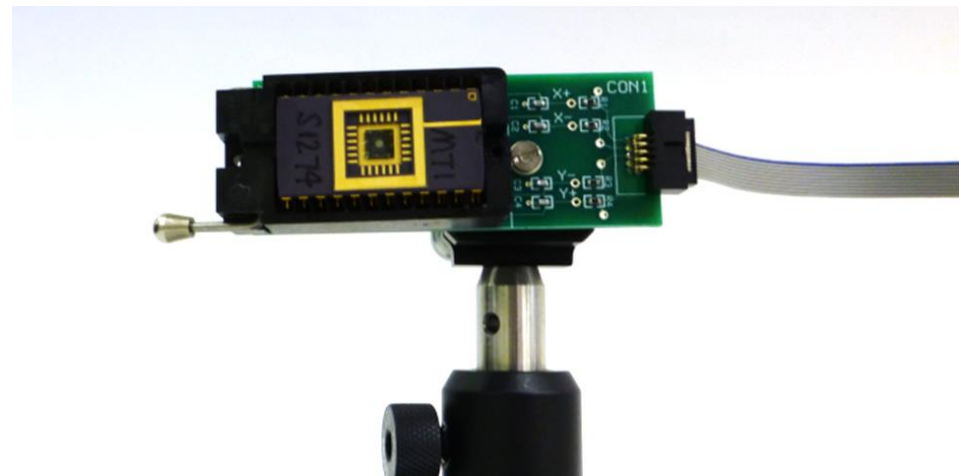
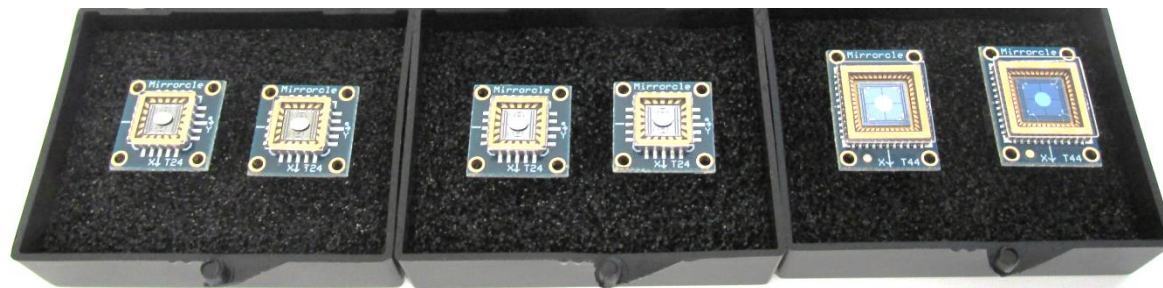



Scan Modules

Mirrorcle Scan Modules

- Mirrorcle Scan Module is a complete opto-mechanical assembly containing a laser, beam-reducing and projection optics, and a fast dual-axis MEMS Mirror
- Mirrorcle currently offers:
 - **EaZy 2.0**
 - **EaZy 3.0**
 - **EaZy 3.1**



EaZy 2.0



EaZy 3.0

EaZy 2.0 MEMS Scan Module

- **MEMS Mirror:** A3I12.2-1200AL
- **Bandwidth:** ~1200Hz in LPF-based driving
- **FoR:** Approx. 40° x 40° Field of Regard
- **Wavelength:** Single laser diode source in:
 - Red (~638nm), <50mW CW power
 - Green (~520nm) , <40mW CW power
 - Blue (~450nm) , <40mW CW power
 - Violet (~405nm) , <40mW CW power
- **Divergence:** <2.0mrad
- **Repeatability:** <0.01° optical each axis
- **MEMS Interface:**
 - 10-pin 0.05" Samtec connector, mates with all Mirrorcle MEMS Controllers and Drivers outputs
- **Laser Interface:**
 - Direct access to TO38 pins of the Laser diode
 - Requires user-provided laser driver to control laser brightness

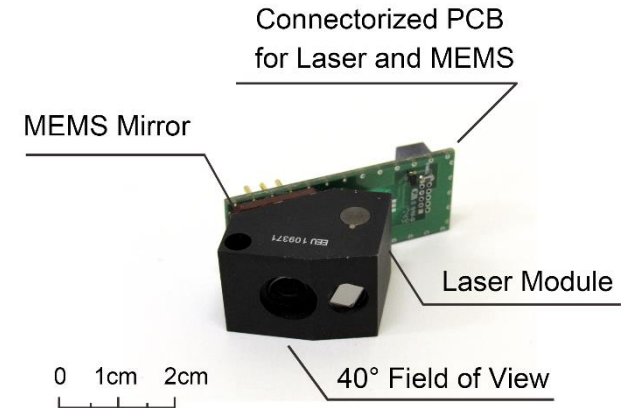

Example application in Player Development Kit

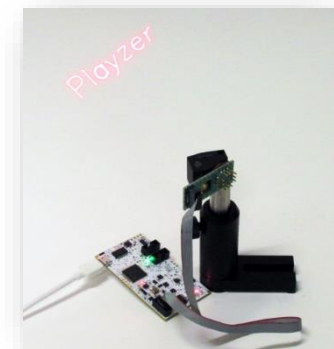

PZDK-01R-OEM

EaZy 3.x MEMS Scan Module

- **MEMS Mirror:** A7M10.2-1000AL
- **Bandwidth:** ~3000Hz in LPF-based driving
- **FoR:** Approx. 40° x 40° Field of Regard
- **Wavelength:** Single laser diode source in:
 - Red (~638nm), <50mW power
 - Green (~520nm) , <40mW power
 - Blue (~450nm) , <40mW power
 - Violet (~405nm) , <40mW power
- **Divergence:** <2.5mrad
- **Repeatability:** <0.01° optical each axis
- **MEMS Interface:**
 - 10-pin 0.05” Samtec connector, mates with all Mirrorcle MEMS Controllers and Drivers outputs
- **Laser Interface:**
 - Direct access to TO38 pins of the Laser diode
 - Requires user-provided laser driver to control laser brightness

0 1cm 2cm

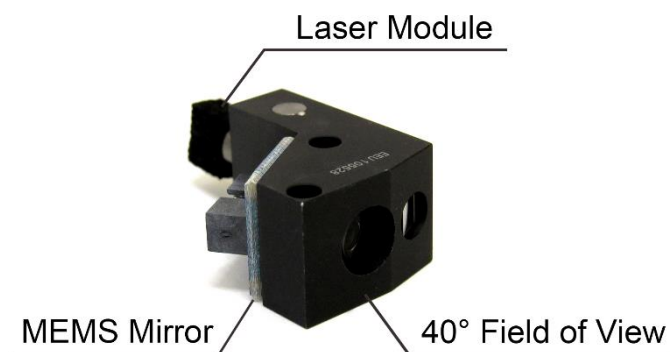

Example vector displays with EaZy 3.0 Scan Modules:





Electronics

Mirrorcle Electronics

□ MEMS Controllers

□ **USB MEMS Controller “USB-SL MZ”**

- Standard, boxed version
- OEM Version

□ **OEM USB MEMS Controller “OCCIE”**

- OEM Version only with **Minimum Order Quantity (MOQ)**

□ MEMS Drivers

□ Digital Input – **“PicoAmp”**

□ Analog Input – **“BDQ PicoAmp”**

□ MEMS Driver Connections Breakout – **“BRK-DRIVER 5.x”**

USB MEMS Controller – “USB-SL MZ”

- ❑ Mirrorcle-designed MEMS Controller with a fast Microchip PIC32MZ MCU
- ❑ Its main function is to interface with user software, store prepared waveforms in a buffer, and run/output those waveforms in open loop to drive the MEMS mirror and peripherals
- ❑ Compatible with latest Software Suite 10.4 and newer
- ❑ Powered and controlled by USB
- ❑ Available as OEM Controller (provided as PCBs with no boxes or cables and require minimum order quantities)

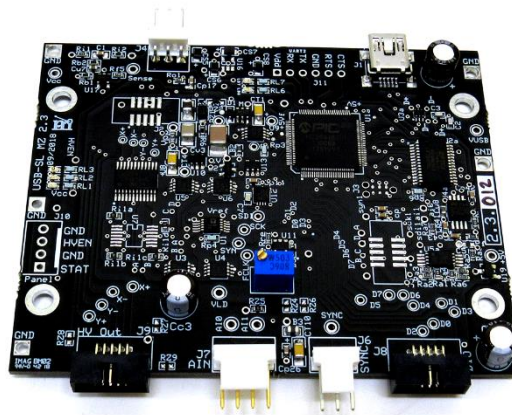

OEM Dimensions: Approx.
87mm x 69mm x 20mm

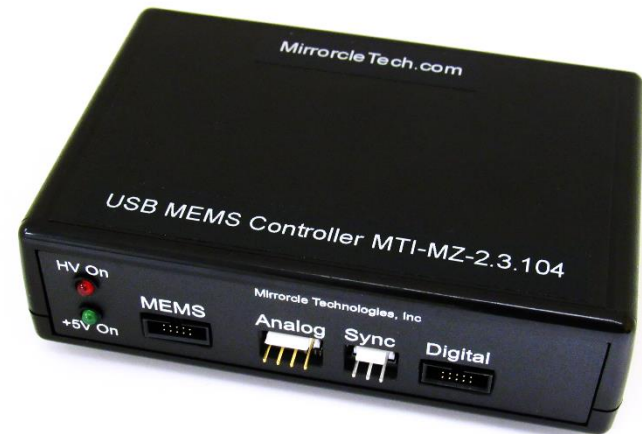

Boxed Dimensions: Approx. 80mm x 115mm x 30mm
Weight: Approx. 140g

USB-SL MZ Features and Specifications

- The USB-SL MZ controller interfaces with Windows Applications for Scan Control and software command that results in MEMS mirror scans and repeatable patterns.
- This product is an open box version of the Development Kit controller
- USB Powered MEMS Controller: USB-SL MZ MEMS Controller
- <1000mW Power Consumption
- Analog Input connector with 2x Analog Inputs
- Digital Output connector with 8 Digital Outputs
- Synchronization Port to trigger lasers, cameras,, etc.
- Sense Port for tracking and imaging applications
- Single PCB Design
- OEM Version provided without box and cables in production quantities (>5 units)

OEM USB MEMS Controller – “OCCIE”

- The **OCCIE** controller interfaces with Windows Applications for Scan Control and software command that results in MEMS mirror scans and repeatable patterns.
- Production-line ready, available in volumes with a 3 month lead time.
- **Features and Specifications:**
 - USB Powered MEMS Controller: OCCIE 1.x
 - <800mW Power Consumption
 - Host Connector with 2 Analog Inputs
 - Host Connector with 4 Digital Synchronization Outputs
 - Digital Output connector with 8 Digital Outputs
- Provided without box and cables in production quantities
- Contact [Mirrorcle sales](#) regarding pricing and **Minimum Order Quantity (MOQ)**

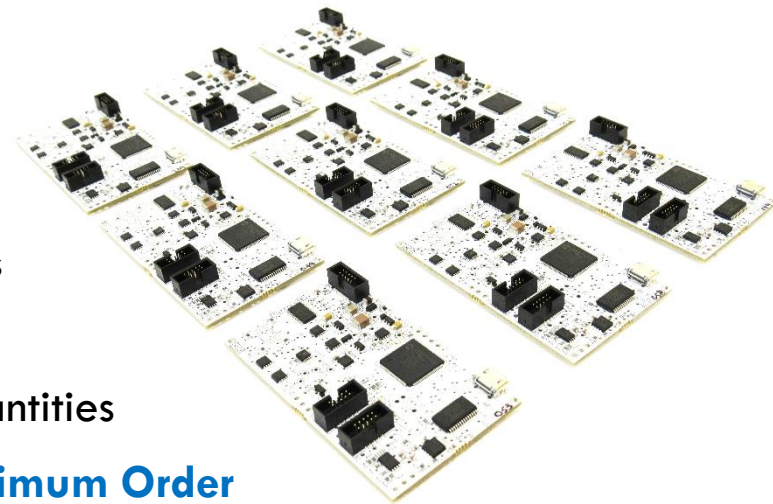

OEM Dimensions: Approx.
70mm x 40mm x 15mm

OEM MEMS Drivers

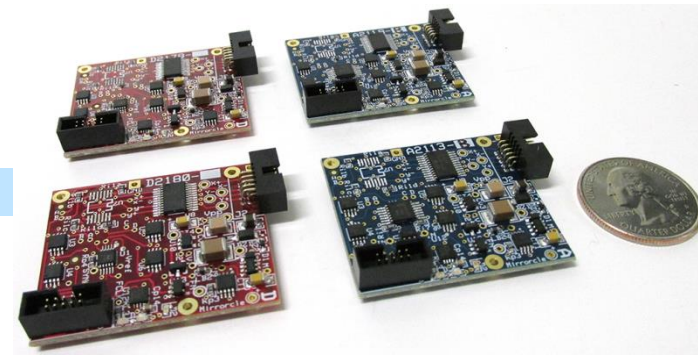

Digital Input

Analog Input

OEM Dimensions: Approx.
35mm x 40mm x 9.3mm

- **Digital Input MEMS Driver - PicoAmp 5.X**
 - 4 unipolar analog outputs $\sim 0V-200V$ (“X200” Drive Mode)
 - 10 pin input for: SPI, MEMS Driver Enable, FCLK_X, FCLK_Y, VDD and GND
 - User controls 4 channels (X+, X-, Y-, Y+) via SPI commands to 16-bit DAC
 - Update rates of up to 250k samples per second are possible for all 4 channels
 - User provides a clock for setting hardware filter cut-off (required)
- **Analog Input MEMS Driver - BDQ PicoAmp 5.X**
 - 4 unipolar analog outputs $\sim 0V-xxx$ (“B160”, “T180” and “X200” Drive Modes)
 - 10 pin input connector for: XIN and YIN Analog Inputs, MEMS Driver Enable, Low-pass Filter Control (FCLK), VDD and GND
 - User controls 4 channels (X+, X-, Y-, Y+) via 2 analog input signals for X and Y axis (with -10V to +10V input range)
 - User provides a clock for setting hardware filter cut-off (required)

Driver Connections Breakout: BRK-DRIVER 5.x

- PCBA which breaks out the input connection side of both digital and analog-input MEMS driver to easy to use terminals or test points / pins. Each pin of the 10-pin connector has its own screw terminal, hook, and hole connection and easy to read label. **Not necessary for production OEM quantities, but bundled with prototyping orders** of Mirrorcle's MEMS Drivers (Ver. 5.x).
- **INPUT:** Screw terminals, test points, connect pins - multiple options for easy connections.
- **OUTPUT:** 10-pin header connector (0.05", 2 rows, right angle) which can be directly connected to MEMS Drivers (Analog and Digital) of 5.x generations.
- This item is offered with prototyping purchases of Mirrorcle MEMS Drivers

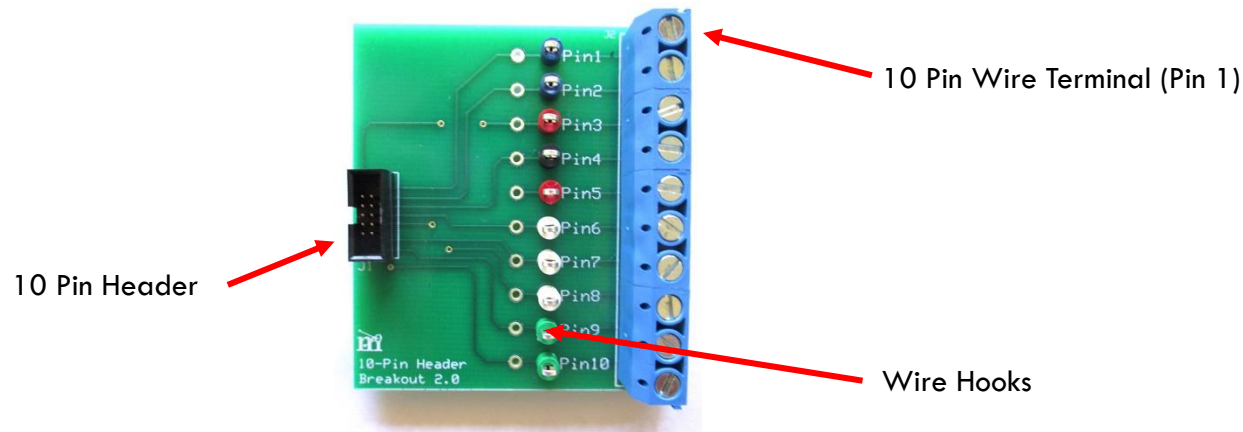



Software

Mirrorcle Software

□ Mirrorcle Software Suite - Windows



- Windows Applications
- C++ SDK
- Matlab SDK
- LabView SDK
- Python SDK

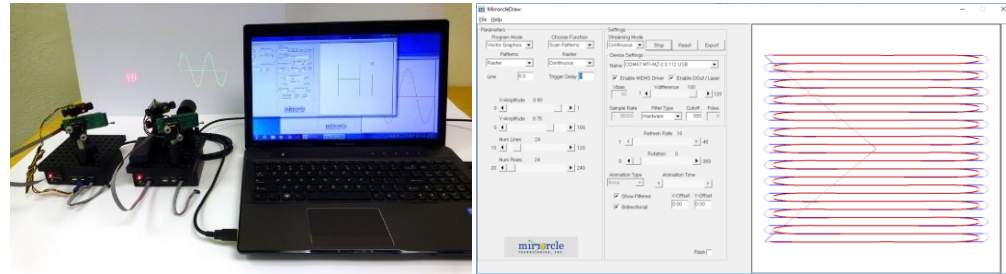

□ Mirrorcle Software Suite - Linux (Raspberry Pi)

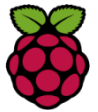

- Built Applications
- C++ SDK
- Python SDK



□ Mirrorcle Software Suite - Android



- Android Applications
- Java on Android SDK

ANDROID



□ MirrorcleILC

- Windows Application

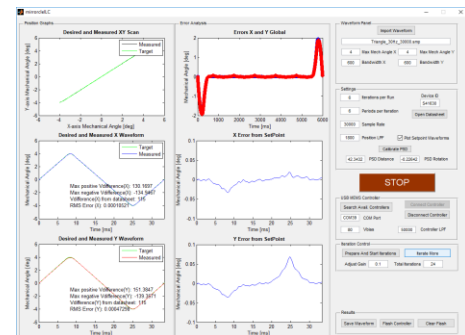

Mirrorcle Software Suite – Windows Applications

MirrorcleDraw is a powerful Windows-based application to control the two axes (tip and tilt) of a MEMS micromirror in a laser-beam steering system to deflect the laser beam in order to create vector images and animations.

- Create **freehand** and **polyline sketches**.
- Parameterized mathematical curves (**Lissajous**, **Spirographs**, **Waveforms**)
- Create **raster patterns** with various settings and rotate to any desired angle
- Display **text** in different fonts and multiple languages.
- Load **ILDA format vector animations** and create custom animations.
- Run the computer as a **two-channel function generator**.
- Select different types of **filters**, **signal-processing** schemes.
- Sample data files (.kpt and .smp) are provided
- Sample ILDA files are provided
- Sample image files are provided

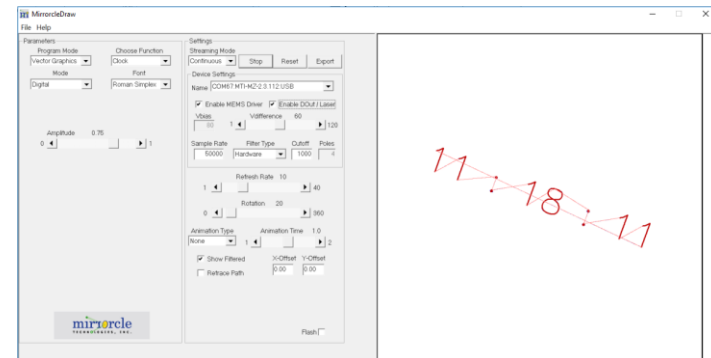
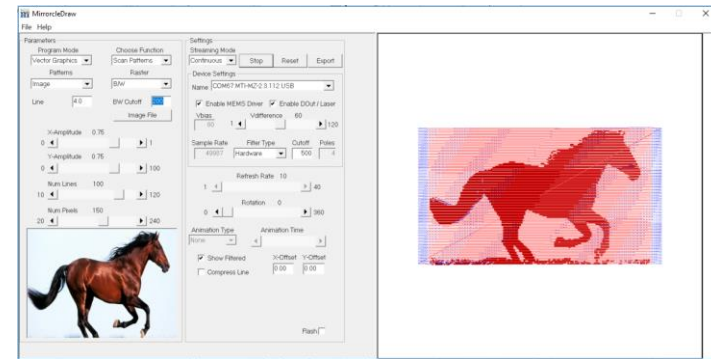

Mirrorcle Software Suite – Windows Applications

□ **MTIDevice-Demo** –

The compiled C++ SDK example project file which demonstrates a variety of ways to drive MEMS mirrors in point to point, scanning, rastering, and other modes.

□ **MirrorcleLinearRaster** –

A command prompt based application that controls the two axes (tip and tilt) of a MEMS mirror in a laser beam steering system to deflect the laser beam in a line by line raster pattern optimal for laser marking, bio-medical imaging and similar applications.

□ **MirrorcleListDevices** –

A small tool to scan the ports for MTL devices. It will report any Mirrorcle MEMS Controllers available for connection whether by USB connection or wireless (Bluetooth) and their respective COM ports.

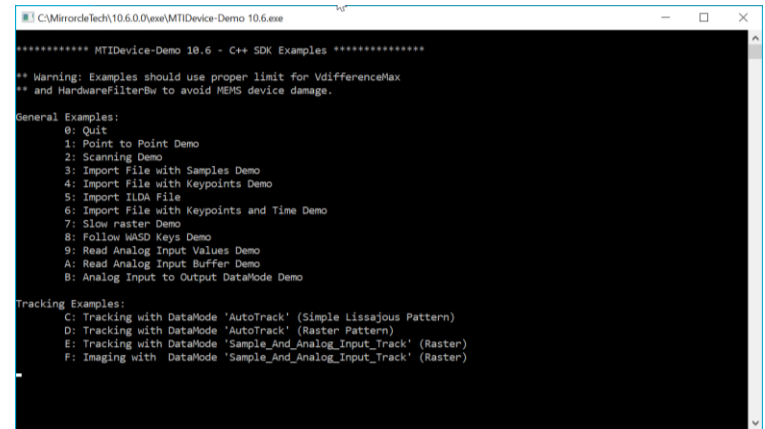

```
***** MTIDevice-Demo 10.6 - C++ SDK Examples *****  
** Warning: Examples should use proper limit for VdifferencMax  
** and HardwareFilterBw to avoid MEMS device damage.  
  
General Examples:  
0: Quit  
1: Point to Point Demo  
2: Scanning Demo  
3: Import File with Samples Demo  
4: Import File with Keypoints Demo  
5: Import IIDA File  
6: Import File with Keypoints and Time Demo  
7: Slow raster Demo  
8: Follow WASD Keys Demo  
9: Read Analog Input Values Demo  
A: Read Analog Input Buffer Demo  
B: Analog Input to Output DataMode Demo  
  
Tracking Examples:  
C: Tracking with DataMode 'AutoTrack' (Simple Lissajous Pattern)  
D: Tracking with DataMode 'AutoTrack' (Raster Pattern)  
E: Tracking with DataMode 'Sample_And_Analog_Input_Track' (Raster)  
F: Imaging with DataMode 'Sample_And_Analog_Input_Track' (Raster)
```

MTIDevice-Demo 10.6

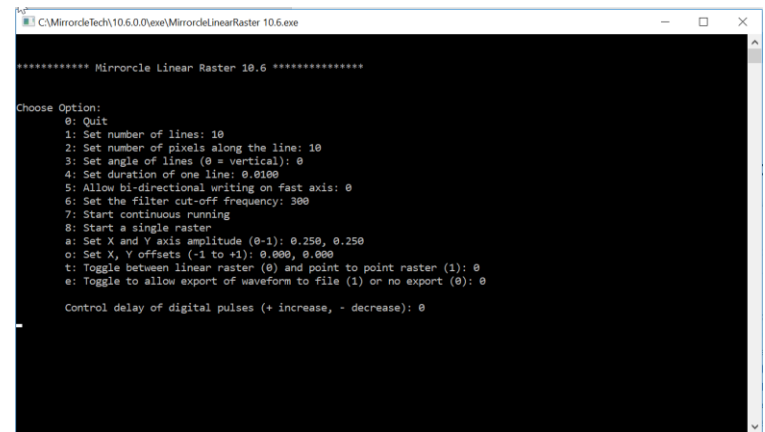

```
***** Mirrorcle Linear Raster 10.6 *****  
  
Choose Option:  
0: Quit  
1: Set number of lines: 10  
2: Set number of pixels along the line: 10  
3: Set angle of lines (0 = vertical): 0  
4: Set duration of one line: 0.0100  
5: Allow bi-directional writing on fast axis: 0  
6: Set the filter cut-off frequency: 300  
7: Start continuous running  
8: Start a single raster  
a: Set X and Y axis amplitude (0-1): 0.250, 0.250  
o: Set X, Y offsets (-1 to +1): 0.000, 0.000  
t: Toggle between linear raster (0) and point to point raster (1): 0  
e: Toggle to allow export of waveform to file (1) or no export (0): 0  
  
Control delay of digital pulses (+ increase, - decrease): 0
```

MirrorcleLinearRaster 10.6

Software Development Kits

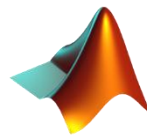
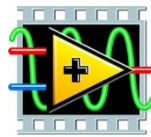

Mirrorcle offers comprehensive Application Programming Interfaces (APIs) for generation of content (MEMS positions and correlated digital outputs), control and streaming of content, reading of analog inputs, synchronization with additional Controllers or peripherals, tracking, etc.

Mirrorcle APIs are available in multiple languages and on various platforms:

- ❑ **Included in the Suite: C++** (Windows and Linux)
- ❑ **Included in the Suite: LabVIEW** (Windows)
- ❑ **Included in the Suite: Matlab** (Windows)
- ❑ **Available Add-On: Python** (Windows and Linux)
- ❑ **Available Add-On: Java** (Android)

Extensive documentation and references are provided at <https://mirrorcletech.com/documentation/>

Thank You for Choosing



If you have any further questions or suggestions please email us:

sales@mirrorcletech.com